



## TECHNICAL DATA

### MASSES

Basic mass	103 kg
Operating mass	104 kg

### COMPACTION

Frequency	90 Hz
Centrifugal force	18 kN
Amplitude	1.63 mm
Water tank volume	7 l

### TRACTION

Max. gradeability	30 %
Max. working speed	25 m/min

### ENGINE

Manufacturer/Model	Hatz 1B20
Emissions according to	Stage V
Type	Air cooled, diesel
Number of cylinders	1
Fuel consumption /h, avg.	0.7 l
Fuel tank capacity	3 l
Power	3.1 kW @ 3000 rpm

### DRIVE SYSTEM

Drive system	Mechanical
--------------	------------

Find us locally at [www.dynapac.com](http://www.dynapac.com)

We reserve the right to change specifications without notice. Photos and illustrations do not always show standard versions of machines. The above information is a general description only, all informations are supplied without liability.



## DIMENSIONS

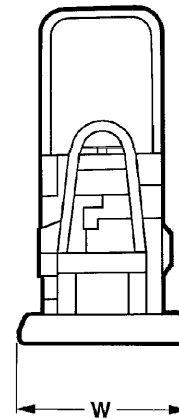
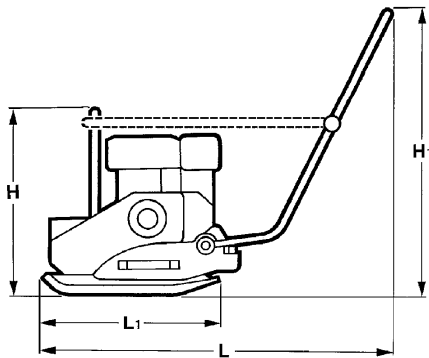

### DIMENSIONS

H. Height	650 mm
H1. Height	915 mm
L. Length	1115 mm
L1. Length	560 mm
W. Basic plate width	450 mm

### STANDARD EQUIPMENT

- Foldable steering handle with vibration isolation
- Highly wear resistant base plate
- Automatic decompression
- All around protection for V-belt
- Protection frame for powerpack
- Recoil starter
- Carrying handles
- One point lift

### OPTIONAL EQUIPMENT

- Water sprinkler system 7l (+7kg)
- Comfort handle
- Puncture proof transport wheels (+4kg)
- Block paving mat
- Service Kit

Find us locally at [www.dynapac.com](http://www.dynapac.com)

We reserve the right to change specifications without notice. Photos and illustrations do not always show standard versions of machines. The above information is a general description only, all informations are supplied without liability.