

REDLINE

Reversible plates

RR150

Technical Data

Masses	
Operating mass	151 kg
Net weight	149 kg
Maximum working speed	20 m/min
Centrifugal force	24 kN
Frequency	92 Hz
Amplitude	92 mm
Centrifugal force	1.65 mm
Dimensions	
Height (H)	690 mm
Height (H1)	1140 mm
Height (H2)	1150 mm
Length (L)	1120 mm
Width plate (W)	500 mm

Engine	
Manufacturer/Model	Honda GX 160
Type	Air cooled, Petrol
Rated power	4.1 kW @ 3600 rpm
Fuel tank capacity	3.6 l
Features	
Control handle with vibration isolation	
Control lever lock in transport position	
Reverse drive protection	
All around protection hood	
All-around protection for V-belt	
One point lift	
Recoil started	
Self-Cleaning Plate Technology	
High wear-resistant forged Base Plate	

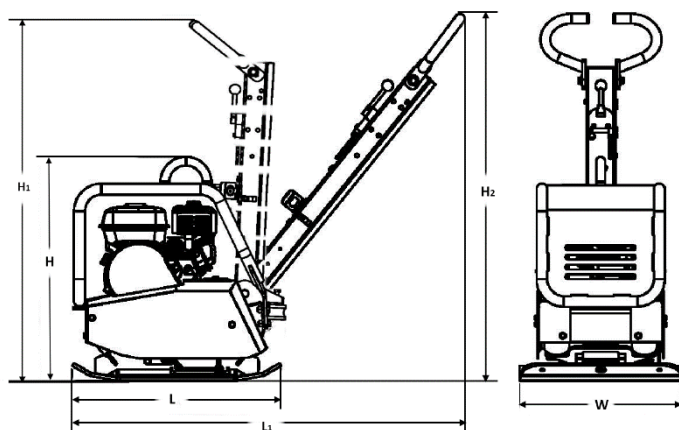

We reserve right to change specifications without notice. Photos and illustrations do not always show standard versions of machines.

The above information is a general description only, all information are supplied without liability.

