

# REDLINE

## Vibrating plates

### RV100

#### Technical Data

##### Masses

Operating mass	104 kg
Basic mass	97 kg

##### Traction

Maximum working speed	24 m/min
Max. Gradability	22 %

##### Compaction

Centrifugal force	19.60 kN
Frequency	93 Hz
Amplitude	0.95 mm

##### Engine

Manufacturer Model	Honda GX 160
Type	Petrol
Power	4.1 kW @ 3,600 rpm

##### Dimensions

Height (H)	580 mm
Height (H1)	621 mm
Height (H2)	904 mm
Length (L)	634 mm
Length plate (L1)	864 mm



##### Features

- Foldable steering handle with vibration isolation
- Highly wear resistance wear plate
- All-round protection for V-belt
- Protection frame for the power pack
- Recoil Starter
- Carrying handles
- One point lift
- Puncture-proof transport wheels

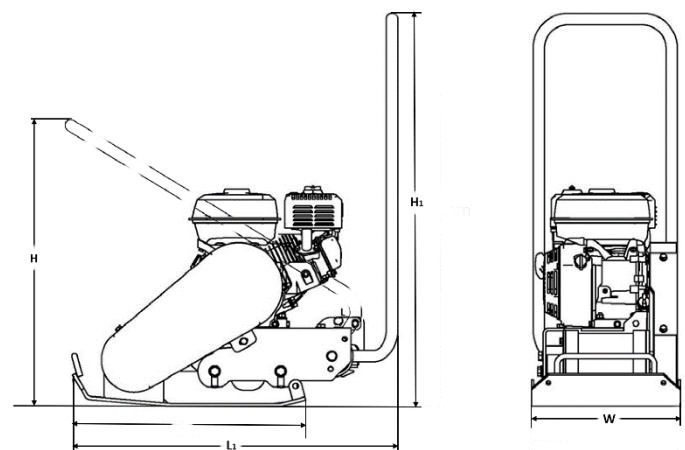

We reserve right to change specifications without notice. Photos and illustrations do not always show standard versions of machines.

The above information is a general description only, all information are supplied without liability.

