

REDLINE

Forward Plates

RV50

Technical Data



Masses

Operating mass	53 kg
Basic mass	50 kg

Traction

Maximum working speed	24 m/min
Max. Gradability	36.4 %

Compaction

Centrifugal force	11 kN
Frequency	100 Hz
Amplitude	2.4 mm

Engine

Manufacturer Model	Honda GX 160
Type	Petrol
Power	4.1 kW @ 3,600 rpm

Dimensions

Height (H)	440 mm
Height (H1)	475 mm
Length (L)	484 mm
Length plate (L1)	760 mm
Width plate	350 mm

Features

- Foldable steering handle with vibration isolation
- Highly wear resistance wear plate
- All-round protection for V-belt
- Protection frame for the power pack
- Carrying handles
- One point lift
- Puncture-proof transport wheels

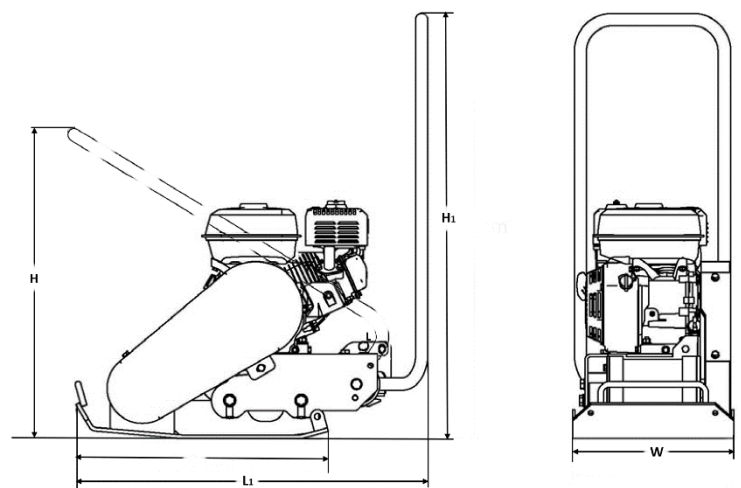

We reserve right to change specifications without notice. Photos and illustrations do not always show standard versions of machines.

The above information is a general description only, all information are supplied without liability.

