

REDLINE Forward Plates

RV80

Technical Data

Masses

Operating mass	78 kg
Basic mass	67 kg

Traction

Maximum working speed	26 m/min
Max. Gradability	36.4 %

Compaction

Centrifugal force	12 kN
Frequency	93 Hz
Amplitude	1.44 mm

Engine

Manufacturer Model	Honda GX 160
Type	Petrol
Power	4.1 kW @ 3,600 rpm

Dimensions

Height (H)	650 mm
Height (H1)	900 mm
Length (L)	550 mm
Length plate (L1)	790 mm
Width plate	350 mm



Features

- Foldable steering handle with vibration isolation
- Highly wear resistance wear plate
- All-round protection for V-belt
- Protection frame for the power pack
- Carrying handles
- One point lift
- Puncture-proof transport wheels

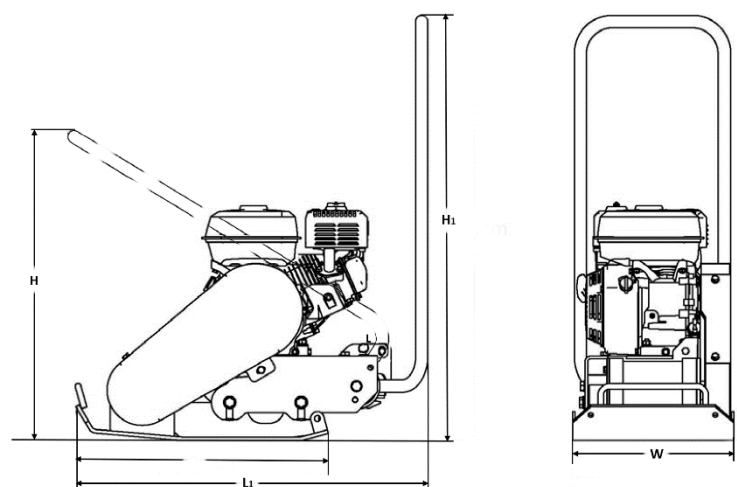

We reserve right to change specifications without notice. Photos and illustrations do not always show standard versions of machines.

The above information is a general description only, all information are supplied without liability.

