

ZAXIS870



HYDRAULIC EXCAVATOR

Model Code : ZX870-5G / ZX870LC-5G / ZX870H-5G / ZX870LCH-5G

Engine Rated Power : 360 kW (483 HP)

Operating Weight : ZX870-5G : 80 800 kg / ZX870LC-5G : 82 600 kg

ZX870H-5G : 82 300 kg / ZX870LCH-5G : 84 200 kg

Backhoe Bucket : ISO Heaped : 2.9 - 4.5 m³

ZAXIS Empower your Vision.

A ZAXIS hallmark – industry-leading hydraulic technologies, and performance no other can beat. New ZAXIS provides reliable solutions: impressive fuel economy, swift front movements, and easy operation. You'll also find Hitachi technological prowess and expertise, such as the optimized hydraulic system and engine.

New ZAXIS features the key benefits of high quality, low fuel consumption, and high durability, all of which serve to ensure low running costs.

New ZAXIS, which is empowered by comprehensive evolution, will realize customers' visions and dreams, and pioneer your colorful future.



Large Production with Less Fuel

Page 4-5

- 4% reduction in fuel consumption
- More fuel reduction in the ECO mode
- Swift front movements with HIOS III B hydraulics
- 9% enhancement in swing torque
- Easy-to-use attachments

No Compromise on Operator Comfort

Page 8-9

- Comfortable operating environment
- Comfort-designed operator seat
- Robust cab
- New, easy-to-use multifunction monitor

Hitachi Support Chain

Page 12-13

- Remote fleet management with Global e-Service
- Parts and service

Pursuits of Performance and Durability

Page 6-7

- Prestige R&D and quality control
- Durable, reliable engine
- Rock-solid, durable front attachment
- Strengthened undercarriage
- Strengthened upperstructure D-section skirt

Simplified Maintenance

Page 10-11

- Concentrated inspection points
- Fast lubrication
- Easy access to the center walkway
- Low life cycle costs
- 1 110 L large capacity fuel tank

ConSite

Page 14-15

- Automatic Data Report Service



Large Production with Less Fuel

4%* Reduction in Fuel Consumption

New ZAXIS is a fuel-thrifty excavator that can reduce fuel consumption by 4%*, compared to the conventional ZX850-3/ ZX850-3F family, thanks to the HIOS III B hydraulic system and engine control system, thereby reducing CO₂ emissions.

*H/P mode vs. conventional model's H/P mode

More Fuel Reduction in the ECO mode

The ECO mode, a new economical mode, can further cut fuel consumption by 10% compared to the PWR mode, without sacrificing digging force by optimal matching of operations.



Swift Front Movements with HIOS* III B Hydraulics

Operating speed increases with less fuel consumption thanks to the HIOS III B hydraulic system, developed by industry-leading hydraulic technologies and a wealth of experience.

*Human & Intelligent Operation System

Improved Arm Controllability

Improved arm controllability for level luffing and level crowding for front movements, including swing operations. The boom regenerative circuit using the boom weight and the newly adopted variable orifice of the swing circuit help ensure hydraulic oil can be effectively allocated and pressure loss can be reduced.

9%* Enhancement in Swing Torque

One of the key performance requirements for mining machinery is swing power. It must be capable of holding and swinging buckets full of crushed stones powerfully, and then loading them onto a dump truck. The new ZAXIS adopts a newly developed swing device to improve swing power by 9%* over conventional models. It also has sufficient capacity to load crushed stones onto a dump truck.

*Compared to the conventional ZX850-3 / ZX850-3F family



Easy-to-Use Attachments

The operator can adjust extra circuit flow and check settings from the multifunction monitor next to the operator seat. What's more, 11 jobs, including flow rate setting, can easily be selected by their identified names.

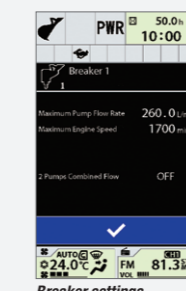

Pursuits of Performance and Durability

Prestige R&D and Quality Control

Hitachi has earned praise for technological prowess and product performance around the world. R&D Division has a track record – including excellent design, stress analysis expertise using CAE system, and abundant production data base. What's more, a large-scale durability test field (427 hm²) allows for a series of stringent testing of new machines. Production Division strives to automatize production processes, including robotic welding, machining, painting, assembling and transferring.

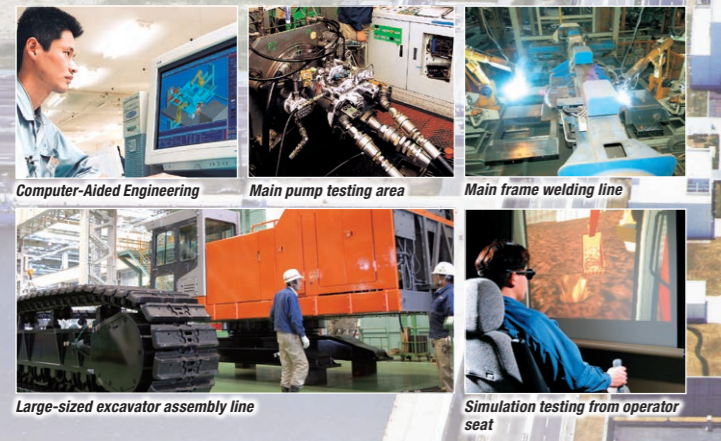

Durable, Reliable Engine

This engine has a track record showing impressive durability at countless tough job sites around the world. The engine — associated with a rugged design, a direct fuel injection system and an elaborate governor — goes green, and complies with EU Stage II and US EPA Tier 2 emissions regulations.

The cooling system has excellent cooling capability with a radiator and oil cooler arranged in parallel. The system optimizes the rotational speed of two cooling fans, depending on the temperatures of coolant and hydraulic oil, contributing to excellent cooling capability and noise reduction. The combination of a 360 kW (483 HP) engine and the new HIOS IIIB hydraulic system meets requirements, in terms of both output and fuel consumption.

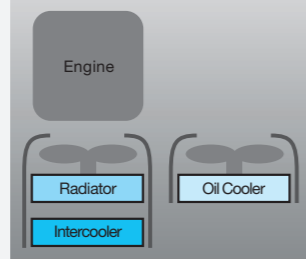

Rock-Solid, Durable Front Attachment

A very robust and durable boom and arm are adopted for the Front Attachment, allowing it to function optimally at tough job sites such as mines / quarries, where an endless stream of operations is required. The ZX870H-5G/ZX870LCH-5G adopts an H-boom and H-arm, using plates thicker than those of standard models. The arm also includes a damage prevention plate and square bars; improving its durability compared to the standard model. The arm cylinder, boom cylinders and bucket cylinder for the retract side cushion shocks at the stroke ends to reduce noise and extend the service life.

Strengthened Undercarriage

The reliable undercarriage structure of the conventional ZAXIS models is retained for the new ZAXIS. For idler brackets, where stress is concentrated in transit, the box-structure and reinforcing plates limit deformation and enhance travel stability. An enhanced two-step side step ladder is also provided to facilitate entering/alighting from the cab.

Strengthened Upperstructure D-Section Skirt

For the new ZAXIS, the plate thickness of the D-section skirt is increased by 25% to improve durability performance. A large door catch is added to reduce shocks and jolts of the cab and upperstructure.



Enhancements of boom & arm with rock bucket (ZX870H-5G / ZX870LCH-5G)

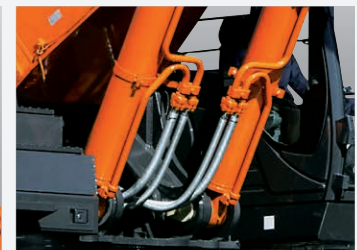

Boom hose protector



Idler brackets



Undercarriage Structure



Side step

No Compromise on Operator Comfort

Comfortable Operating Environment

You'll feel comfortable and confident, with plenty of leg space and excellent visibility when entering the cab. The new compact console gives more leg space. The new door pillar is shifted rearward by 70 mm to widen an entry space for easy access. A new LED room light, interlocked with the door, turns on when the door opens. The front window is easily removed and stored overhead using slide rails (ZX870(LC)-5G only). The overhead window is openable for ventilation. Lots more air vents for air conditioner are located strategically for uniform air circulation inside the cab. The control panel and control levers are arranged within easy reach of the operator. AM/FM radio and AUX port (optional) for a mobile music player are available for a long work day with less fatigue. All these designs focus on operator comfort.

Comfort-Designed Operator Seat

The luxury cloth seat is fitted with a headrest and arm rests for operator comfort. The seat can be adjusted in multiple ways, sliding and reclining, to suit operator's size and preferences. The seat can slide rearward by 40 mm more for added leg space. An air suspension with a heat pad is optional.

Robust Cab

The robust cab, meeting the OPG (Top Guard Level 1*), protects the operator from falling objects. The pilot control shut-off lever is provided with the neutral engine start system that permits engine starting only when the pilot control shut-off lever is in Lock position. The engine is lockable by entering a password through the 10-key panel.

*The H-series complies with Top Guard Level II.



Control panel

Large storage space



The photo shows an optional air suspension seat

New, Easy-to-Use Multifunction Monitor

The new multi-language, multifunction monitoring system is composed of a 7-inch high-resolution color monitor and a multifunction controller. The monitor allows the operator to check varying operating variables: oil temperature, fuel level, work mode, full-auto air conditioner, AM/FM radio, rear view monitor camera (optional), maintenance support, and attachment flow adjustment. Menu items can be selected and adjusted by a multifunction controller on the control panel. A new rear view monitor camera always displays the view behind the machine.



Simplified Maintenance



Concentrated Inspection Points

Inspection points are concentrated on the wall surface around the engine and the center walkway located in the center of the upperstructure. This facilitates maintenance of the engine oil filter, fuel filter, pilot filter, drain filter and water separator. A lid behind the cab door is available for easy replacement of the air conditioner filters for fresh air.

Easy Access to the Center Walkway

The center walkway is located in the center of the upperstructure for easy access to the engine and inspection points. The center walkway is easily accessible from a wide side walkway and features anti-skid plates for safety.

Fast Lubrication

The arm and boom have their own centralized greasing points for fast lubrication. An optional electric grease gun with hose-reel or an auto-grease lubricator is also available for faster greasing / lubrication.

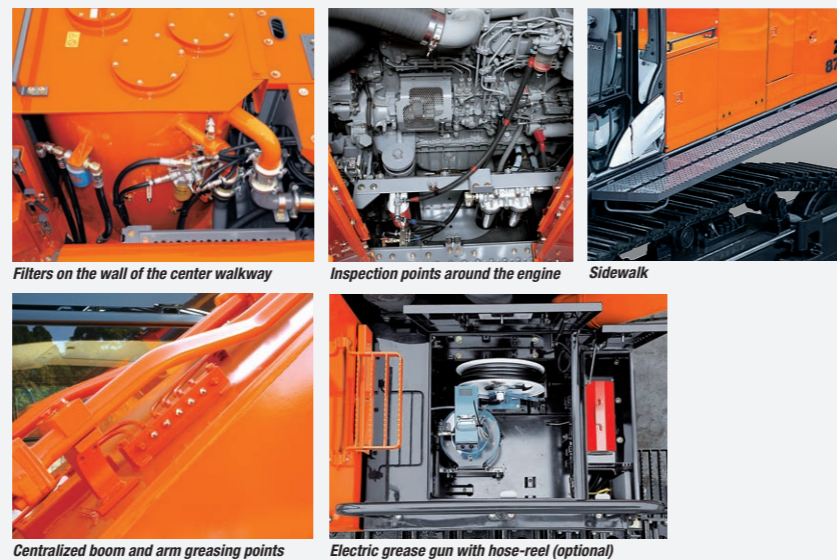

Low Life Cycle Costs

Service intervals are long enough to slash maintenance costs.

1 110 L Large Capacity Fuel Tank

Equipped with a large capacity fuel tank for longer operations.

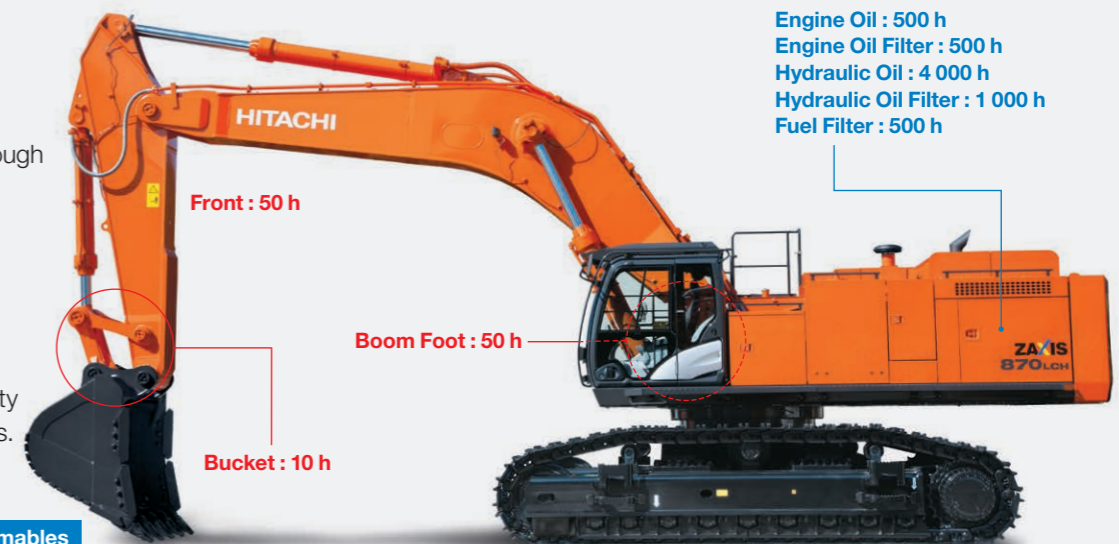

Lubricant Consumables

Note: Periodic inspection is required to check oil contamination and likes.

Hitachi Support Chain

Hitachi Support Chain is a full customer support system offered after buying a Hitachi machine.

Remote Fleet Management with Global e-Service

Easy Access to On-Site Machines through the Internet

This on-line fleet management system allows you to access each on-site machine from a PC in your office. You can get its operating information and location to increase productivity of the fleet and reduce downtime. Operating data and log are sent to a Hitachi server for processing, and then to customer and dealers around the world. This system is available 24 hours a day, all the year around.

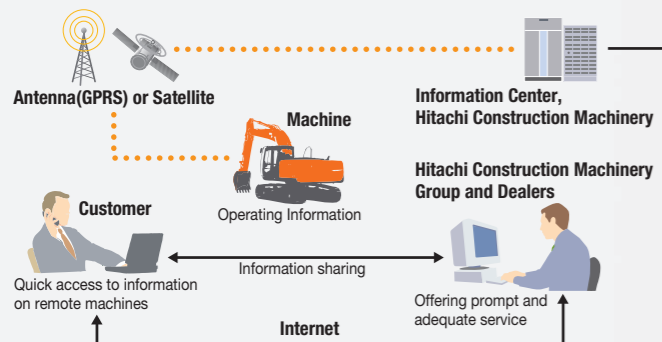

Note: In Some Regions, Global e-Service Is Not Available by Local Regulations.

Main Features of Global e-Service

Functions

Global e-Service provides easy access to a machine on site, conveying operating information and log, including daily operating hours, fuel level, temperatures, pressures, and likes.

Maintenance

Maintenance data and log are displayed on a easy-to-read monitor screen, suggesting recommended maintenance for efficient fleet management.

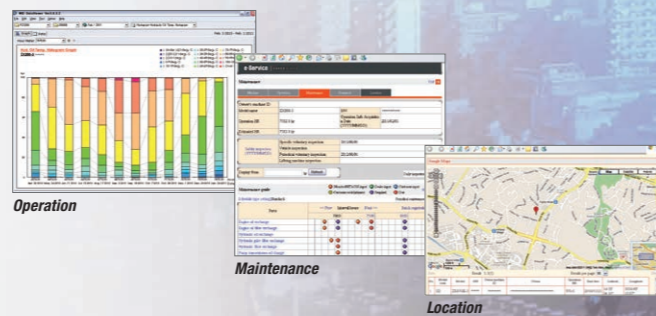

Parts and Service

Hitachi full customer support is available every area on the globe for full customer satisfaction through Hitachi local dealers.

Parts

Hitachi Global Online Network, a parts supply system, is linked with Japan Parts Center, overseas depots and over 150 dealers abroad to deliver on-line parts information, including in-stock parts, order receptions, shipments and delivery period of over one million parts and components.

Genuine Hitachi Parts

Genuine Hitachi parts, meeting Hitachi stringent quality standards, are guaranteed according to Hitachi warranty standards. The use of genuine Hitachi parts, including engine, fuel, hydraulic oil and filters, may slash running costs, and extend machine life.

Ground Engaging Tools (GETs)

Hitachi provides an array of Hitachi Ground Engaging Tools developed and built for a variety of applications. Using high-

quality, well-maintained GETs will help you get customers' trust.

Note: Some dealers do not handle Hitachi GETs.

Remanufactured Components

Hitachi components are remanufactured according to the stringent remanufacturing standards at four factories around the world. They have high quality equivalent to new ones, and backed up by Hitachi warranty system.

Note: Some dealers do not handle Hitachi Remanufactured Components.

Service

Extended Warranty — HELP

Hitachi Standard Warranty System is available on all new Hitachi machines. In addition, Hitachi offers Hitachi Extended Life Programs (HELPS) to suit customer expectations —

protecting machines under tough operating conditions, avoiding unexpected downtime, and reducing repair costs.

Note: Warranty conditions vary by equipment.

Diagnostic Tools — Maintenance Pro

Electronic control system needs quick on-site solutions, apart from mechanical repairs. Hitachi's Maintenance Pro can diagnose machine failures in a short time by plugging a PC into a failed machine.

Technical Training

On-site servicing matters despite locations to keep the machine at peak performance and reduce downtime. Technical Training Center (TTC), located in Japan, educates and trains service technicians and service support personnel coming from Hitachi dealers and factories on the globe according to the international training programs.

ConSite

ConSite is an automatic Data Report Service that sends a monthly e-mail summarising the information from Global e-Service for each of your Hitachi machines.

Available in more than 30 languages, ConSite includes a detailed analysis of the operational data, ratios and hours. This Monthly Report is also stored on the Owner's Site for ease of reference.



A remote fleet monitoring system to improve overall performance

ConSite

Our ConSite Data Report Service sends you a monthly e-mail to summarise the information available on Global e-Service for each of your Hitachi machines. It includes a detailed analysis of operational data, ratios and hours, so you can see how productive and efficient your machines have been in the past month. All the information from the report is stored in the Owner's Site as well, for easy reference.

Further into the ConSite Report, you'll see non-operation and swing efficiency ratings and ratios. These compare the machine's performance against the same model class from all Hitachi owners in your region.

The monthly and total number of hours are divided for front, swing, travel and attachment operations. This will help you to determine the actual usage of your machine and maintenance planning. The monthly analysis of these variables is compared to the total lifetime of the machine in a user-friendly chart. A line graph shows the actual and projected number of hours, which helps you to manage maintenance requirements.

ConSite can also help you in the unlikely event of a fault. It will send you and your authorised Hitachi dealer an Emergency Alarm Report, so you can both respond quickly in order to minimise unscheduled downtime.

We created ConSite to improve your business operations, and enable you to analyze the productivity and efficiency of your equipment. The information it provides on machine usage is intended to help you with maintenance planning and also promotes proactive support from your dealer. Ultimately, it provides you with confidence in your Hitachi construction equipment and peace of mind to focus on other areas of your business.

Owner's Site

You can find out all you need to know about your fleet of Hitachi construction machinery in the field from the comfort of your home or office, thanks to Owner's Site. This online management tool, available at www.globaleservice.com, is user-friendly and offers extensive and detailed information on your Hitachi Zaxis Excavators and ZW Wheel Loaders.

The data is displayed in a flexible layout, so you can create machine groups per job site or select relevant information, depending on your requirements. As every project is different, you can customize the Owner's Site Dashboard to view data quickly and easily.



Scan this code for our ConSite function explanation & case study video

ConSite
Consolidated Solution for Construction Sites

Key Features

- Check each of your machines from your office – 24/7
- Have a remote insight into fuel consumption
- Check the current and previous locations and movements of your machine(s)
- See maintenance status and items due for renewal on each of your machines
- Receive e-mail notifications for any machine alerts, unexpected movements and so on

SPECIFICATIONS

ENGINE

Model	Isuzu BB-6WG1XQA-04
Type	4-cycle water-cooled, direct injection
Aspiration	Turbocharged, intercooled
No. of cylinders	6
Rated power	
ISO 9249, net	H/P mode:
(Without Fan)	360 kW (483 HP) at 1 800 min ⁻¹ (rpm)
SAE J1349, net	H/P mode:
(Without Fan)	360 kW (483 HP) at 1 800 min ⁻¹ (rpm)
Maximum torque	1 945 Nm (198 kgf m) at 1 500 min ⁻¹ (rpm)
Piston displacement ..	15.681 L
Bore and stroke	147 mm x 154 mm
Batteries	2 x 12 V / 170 Ah

HYDRAULIC SYSTEM

Hydraulic Pumps

Main pumps	2 variable displacement axial piston pumps
Maximum oil flow ..	2 x 512 L/min
Pilot pump	1 gear pump
Maximum oil flow ..	50 L/min

Hydraulic Motors

Travel	2 axial piston motors with parking brake
Swing	2 axial piston motors

Relief Valve Settings

Implement circuit	31.9 MPa (325 kgf/cm ²)
Swing circuit	28.4 MPa (290 kgf/cm ²)
Travel circuit	34.3 MPa (350 kgf/cm ²)
Pilot circuit	3.9 MPa (40 kgf/cm ²)
Power boost	34.3 MPa (350 kgf/cm ²)

Hydraulic Cylinders

	Quantity	Bore	Rod diameter
Boom	2	215 mm	150 mm
Arm	1	225 mm	160 mm
Bucket	1	200 mm	140 mm
Bucket BE	1	215 mm	150 mm

UPPERSTRUCTURE

Revolving Frame

D-section frame for resistance to deformation.

Swing Device

Axial piston motor with planetary reduction gear is bathed in oil. Swing parking brake is spring-set/hydraulic-released disc type.

Swing speed	7.4 min ⁻¹ (rpm)
-------------------	-----------------------------

Operator's Cab

ZX870-5G / ZX870LC-5G:

Independent spacious cab, 1 025 mm wide by 1 675 mm high. The OPG top guard fitted Level I conforms to the related requirements of the International Organization Standardization(ISO)10262.

ZX870H-5G / ZX870LCH-5G (H/R cab):

Independent spacious cab, 1 025 mm wide by 1 817 mm high. The OPG top guard fitted Level II conforms to the related requirements of the International Organization Standardization(ISO)10262.

UNDERCARRIAGE

Tracks

Track shoes with double grousers made of induction-hardened rolled alloy. Heat-treated connecting pins with dirt seals. Hydraulic (grease) track adjusters with shock-absorbing recoil springs.

Numbers of Rollers and Shoes on Each Side

Upper rollers	3
Lower rollers	8: ZX870-5G / ZX870H-5G 9: ZX870LC-5G / ZX870LCH-5G
Track shoes	47: ZX870-5G / ZX870H-5G 51: ZX870LC-5G / ZX870LCH-5G
Idler track guard	1
Track guard	2: ZX870-5G / ZX870LC-5G Full track guard: ZX870H-5G / ZX870LCH-5G

Travel Device

Each track driven by axial piston motor through reduction gear for counterrotation of the tracks. Parking brake is spring-set/hydraulic-released disc type.

Automatic transmission system: High-Low.

Travel speeds	High : 0 to 4.5 km/h Low : 0 to 3.0 km/h
---------------------	---

Maximum traction force ..	560 kN (57 100 kgf)
---------------------------	---------------------

Gradeability	70% (35 degree) continuous
--------------------	----------------------------

SERVICE REFILL CAPACITIES

Fuel tank	1110.0 L
Engine coolant	112.0 L
Engine oil	52.0 L
Pump device	6.2 L
Swing device (each side)	15.7 L
Travel device (each side)	19.0 L
Hydraulic system	1042.0 L
Hydraulic oil tank	500.0 L

WEIGHTS AND GROUND PRESSURE

Operating Weight and Ground Pressure

Shoe type	Shoe width	Boom type	Arm type	ZX870-5G		ZX870LC-5G		ZX870H-5G		ZX870LCH-5G		
				kg	kPa (kgf/cm ²)	kg	kPa (kgf/cm ²)	kg	kPa (kgf/cm ²)	kg	kPa (kgf/cm ²)	
Double	650 mm	8.4 m	4.4 m	80 700	121 (1.23)	82 500	112 (1.14)	-	-	-	-	
				Bucket capacity		2.90 m ³		2.90 m ³		-	-	-
		8.4 m	3.7 m	80 700	121 (1.23)	82 400	112 (1.14)	-	-	-	-	
				Bucket capacity		3.50 m ³		3.50 m ³		-	-	-
		8.4 m H	3.7 m H	-	-	-	-	82 300	124 (1.26)	84 200	115 (1.17)	
				Bucket capacity		-		3.50 m ³ Rock bucket		3.50 m ³ Rock bucket		
		7.1 m BE	3.7 m H	-	-	-	-	81 900	123 (1.25)	83 800	114 (1.16)	
				Bucket capacity		-		3.70 m ³ Rock bucket		3.70 m ³ Rock bucket		
		7.1 m BE	2.95 m BE	81 500	122 (1.25)	83 300	113 (1.15)	82 500	124 (1.26)	84 400	115 (1.17)	
				Bucket capacity		4.50 m ³		4.50 m ³		4.30 m ³ Rock bucket		4.30 m ³ Rock bucket
		750 mm	8.4 m	4.4 m	81 400	106 (1.08)	83 200	98 (1.00)	-	-	-	-
					Bucket capacity		2.90 m ³		2.90 m ³		-	-
	8.4 m		3.7 m	81 300	106 (1.08)	83 100	98 (1.00)	-	-	-	-	
				Bucket capacity		3.50 m ³		3.50 m ³		-	-	-
	7.1 m BE		2.95 m BE	82 100	107 (1.09)	84 000	99 (1.01)	-	-	-	-	
				Bucket capacity		4.50 m ³		4.50 m ³		-	-	-
	900 mm		8.4 m	4.4 m	-	-	84 100	83 (0.84)	-	-	-	-
					Bucket capacity		-		2.90 m ³		-	-
			8.4 m	3.7 m	-	-	84 200	83 (0.84)	-	-	-	-
					Bucket capacity		-		3.50 m ³		-	-
			7.1 m BE	2.95 m BE	-	-	84 900	83 (0.85)	-	-	-	-
					Bucket capacity		-		4.50 m ³		-	-

BUCKET LIST

ZX870-5G / ZX870LC-5G

Capacity	Width		No. of teeth	Weight	Recommendation		
	Without side cutters	With side cutters			7.1 m BE-boom 2.95 m BE-arm	3.7 m arm	8.4 m boom 4.4 m arm
2.90 m ³	1 590 mm	1 780 mm	5	2 700 kg	x	⊙	⊙
3.50 m ³	1 850 mm	2 040 mm	5	2 950 kg	x	⊙	-
4.50 m ³	2 120 mm	2 190 mm	5	3 970 kg	⊙	x	x
Applicable shoe type					650 mm Double grouser		
					750 mm Double grouser		
					900 mm Double grouser : ZX870LC-5G		

⊙ Suitable for material with density of 1 800 kg / m³ or less

- Not applicable

x Can't be installed

ZX870H-5G / ZX870LCH-5G

Capacity	Width		No. of teeth	Weight	Recommendation		
	Without side cutters	With side cutters			7.1 m BE-boom 2.95 m BE-arm	3.7 m H-arm	8.4 m H-boom 3.7 m H-arm
*1 3.50 m ³	1 870 mm	1 890 mm	5	3 790 kg	x	●	●
*1 3.70 m ³	1 950 mm	1 970 mm	5	3 900 kg	x	●	x
*1 4.30 m ³	2 090 mm	2 110 mm	5	4 270 kg	●	x	x
*2 1.90 m ³	-	1 490 mm	3	4 200 kg	x	●	●
*2 2.20 m ³	-	1 580 mm	3	4 400 kg	●	x	x
One-point ripper			1	2 680 kg	●	●	●
Applicable shoe type					650 mm Double grouser		

*1 Rock bucket *2 Ripper bucket

● Heavy-duty service

x Can't be installed

SPECIFICATIONS

WORKING RANGES

ZX870-5G / ZX870LC-5G

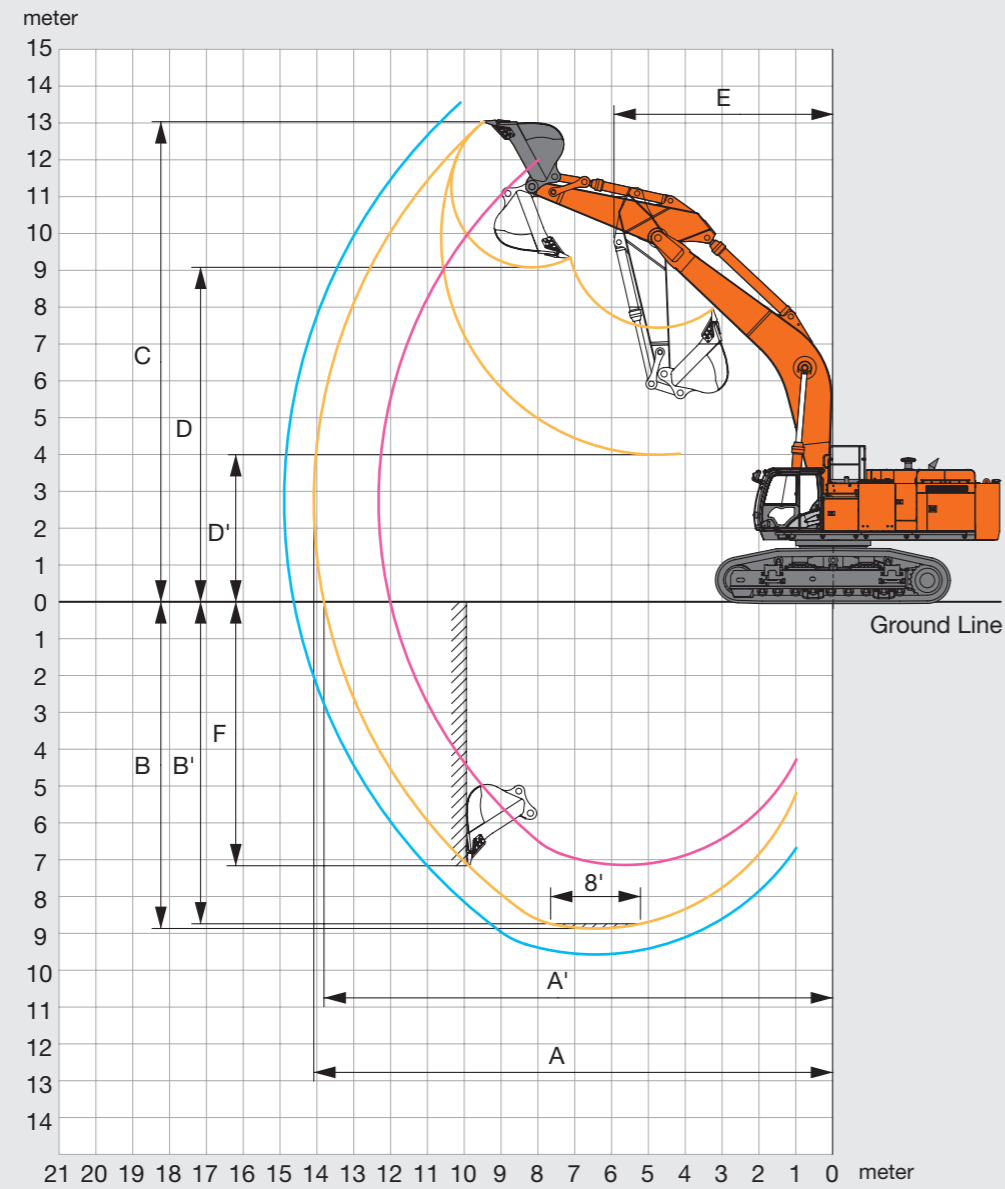

Unit: mm

	ZX870-5G / ZX870LC-5G		
	7.1 m BE-boom	8.4 m boom	
	2.95 m BE-arm	3.7 m arm	4.4 m arm
A Max. digging reach	12 340	14 100	14 910
A' Max. digging reach (on ground)	12 020	13 820	14 640
B Max. digging depth	7 140	8 870	9 570
B' Max. digging depth (8' level)	7 000	8 740	9 460
C Max. cutting height	12 010	13 030	13 820
D Max. dumping height	8 130	9 080	9 740
D' Min. dumping height	3 770	3 990	3 290
E Min. swing radius	5 210	5 950	5 950
F Max. vertical wall	4 100	7 170	8 480

Excluding track shoe lug

WORKING RANGES

ZX870H-5G / ZX870LCH-5G

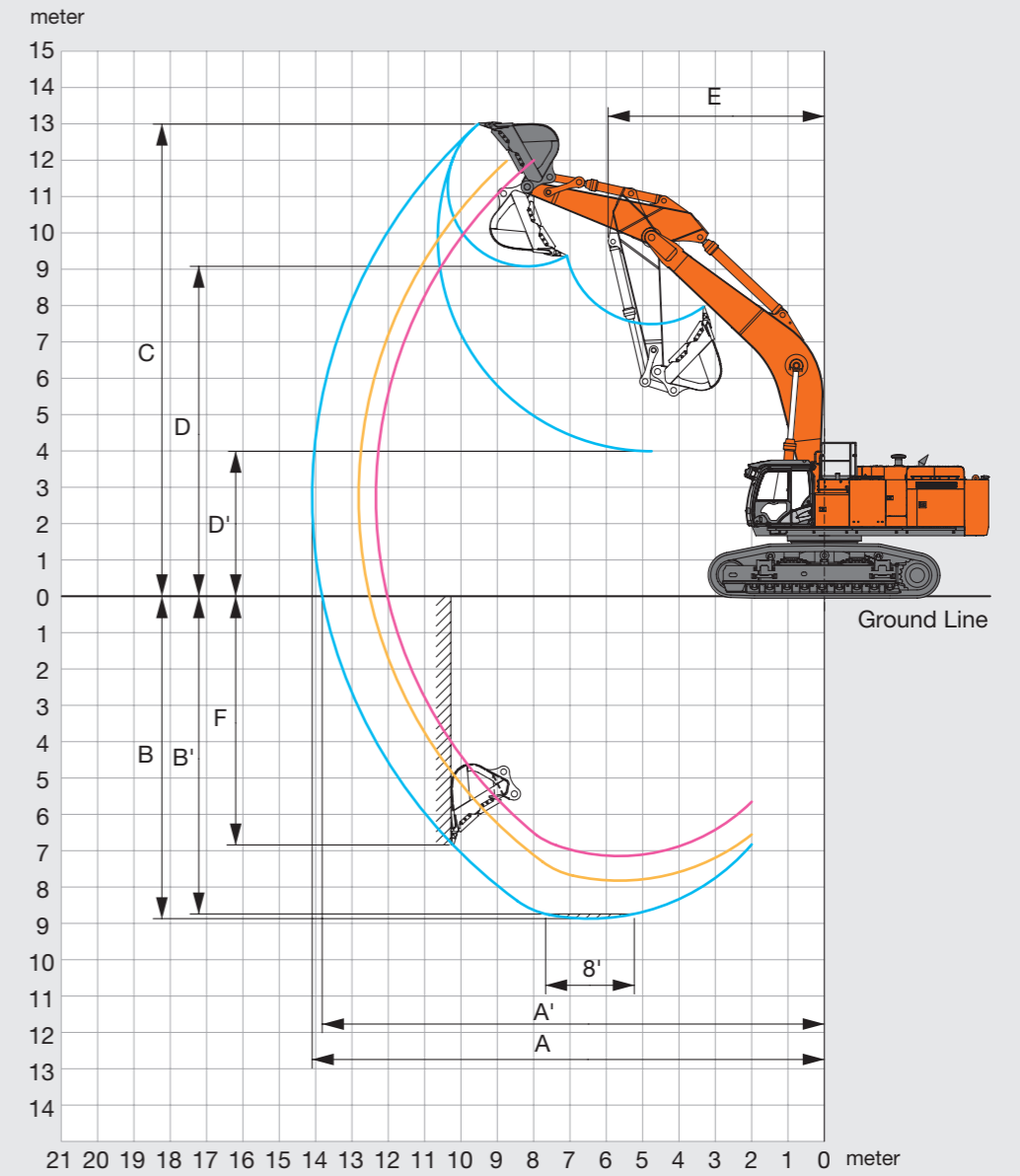

Unit: mm

	ZX870H-5G / ZX870LCH-5G		
	7.1 m BE-boom	8.4 m H-boom	
	2.95 m BE-arm	3.7 m H-arm	3.7 m H-arm
A Max. digging reach	12 340	12 820	14 100
A' Max. digging reach (on ground)	12 020	12 510	13 820
B Max. digging depth	7 140	7 820	8 870
B' Max. digging depth (8' level)	7 000	7 690	8 740
C Max. cutting height	12 010	12 130	13 000
D Max. dumping height	8 130	8 180	9 080
D' Min. dumping height	3 770	3 000	3 990
E Min. swing radius	5 210	5 090	5 950
F Max. vertical wall	4 100	6 090	6 840

Excluding track shoe lug

SPECIFICATIONS

DIMENSIONS

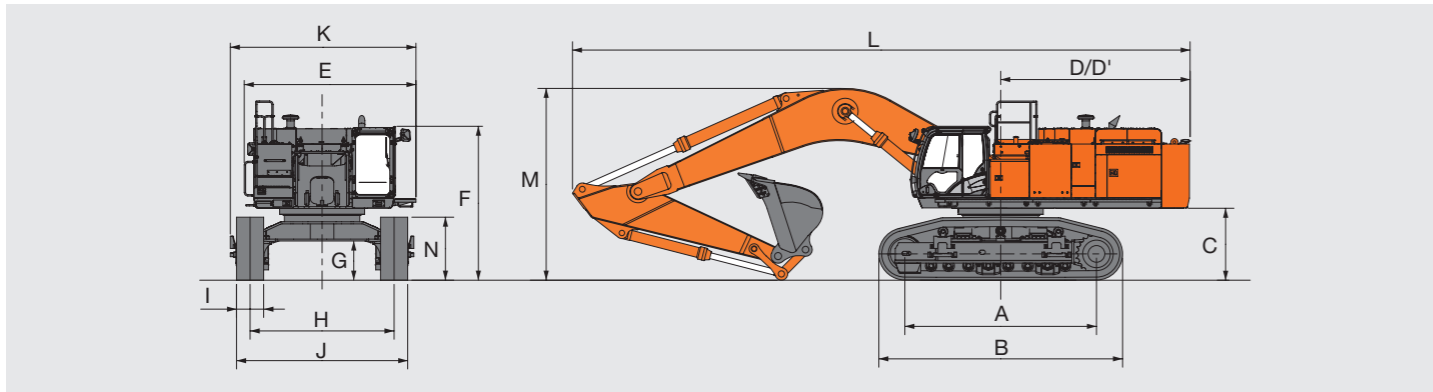

Unit: mm

Retractable gauge	ZX870-5G	ZX870LC-5G	ZX870H-5G	ZX870LCH-5G
A Distance between tumbler	4 590	5 110	4 590	5 110
B Undercarriage length	5 840	6 360	5 840	6 360
*1 C Counterweight clearance	1 680	1 680	1 680	1 680
D Rear-end swing radius	4 600	4 600	4 600	4 600
D' Rear-end length	4 520	4 520	4 520	4 520
E Overall width upperstructure	4 120	4 120	4 120	4 120
F Overall height of cab	3 690	3 690	3 800	3 800
*1 G Min. ground clearance	890	890	890	890
H Track gauge: Extended / Retracted	3 450 / 2 830	3 450 / 2 830	3 450 / 2 830	3 450 / 2 830
I Track shoe width	650 / 750	650 / 750 / 900	650	650
J Undercarriage width with 650 mm shoe	4 100 / 3 480	4 100 / 3 480	4 100 / 3 480	4 100 / 3 480
: Extended / Retracted with 750 mm shoe	4 200 / 3 580	4 200 / 3 580	—	—
with 900 mm shoe	—	4 350 / 3 730	—	—
K Overall width	4 450	4 450	4 450	4 450
L Overall length	14 800	14 800	14 800	14 800
M Overall height of boom	4 770	4 770	4 770	4 770
N Track height	1 500	1 500	1 500	1 500

*1 Excluding track shoe lug

BUCKET AND ARM DIGGING FORCES

ZX870-5G / ZX870LC-5G

	ZX870-5G / ZX870LC-5G		
	7.1m BE-boom	8.4 m boom	
	2.95 m BE-arm	3.7 m arm	4.4 m arm
Bucket digging force* ISO	472 kN (48 200 kgf)	399 kN (40 700 kgf)	399 kN (40 700 kgf)
Bucket digging force*SAE : PCSA	411 kN (41 900 kgf)	359 kN (36 600 kgf)	359 kN (36 600 kgf)
Arm crowd force* ISO	394 kN (40 200 kgf)	323 kN (33 000 kgf)	280 kN (28 600 kgf)
Arm crowd force* SAE : PCSA	378 kN (38 600 kgf)	315 kN (32 100 kgf)	273 kN (27 900 kgf)

*At power boost

ZX870H-5G / ZX870LCH-5G

	ZX870H-5G / ZX870LCH-5G		
	7.1 m BE-boom		8.4 m H-boom
	2.95 m BE-arm	3.7 m H-arm	3.7 m H-arm
Bucket digging force* ISO	472 kN (48 200 kgf)	402 kN (41 000 kgf)	402 kN (41 000 kgf)
Bucket digging force*SAE : PCSA	411 kN (41 900 kgf)	359 kN (36 600 kgf)	359 kN (36 600 kgf)
Arm crowd force* ISO	394 kN (40 200 kgf)	324 kN (33 100 kgf)	324 kN (33 100 kgf)
Arm crowd force* SAE : PCSA	378 kN (38 600 kgf)	316 kN (32 200 kgf)	316 kN (32 200 kgf)

*At power boost

LIFTING CAPACITIES (Without bucket)

Notes: 1. Ratings are based on ISO 10567.

2. Lifting capacity does not exceed 75% of tipping load with the machine on firm, level ground or 87% full hydraulic capacity.

3. The load point is the center-line of the bucket pivot mounting pin on the arm.

4. *Indicates load limited by hydraulic capacity.

5. 0 m = Ground.

For lifting capacities, subtract bucket and quick hitch weight from lifting capacities without bucket.

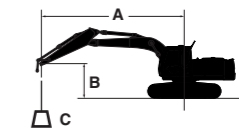

A: Load radius

B: Load point height

C: Lifting capacity

ZX870LC-5G

Rating over-front Rating over-side or 360 degrees Unit : kg

Conditions	Load point height m	Load radius m												At max. reach				
		3.0		4.5		6.0		7.5		9.0		10.5		12.0		meter		
		Rating over-front	Rating over-side or 360 degrees	Rating over-front	Rating over-side or 360 degrees	Rating over-front	Rating over-side or 360 degrees	Rating over-front	Rating over-side or 360 degrees	Rating over-front	Rating over-side or 360 degrees	Rating over-front	Rating over-side or 360 degrees	Rating over-front	Rating over-side or 360 degrees	meter	meter	
BE-Boom 7.1 m BE-Arm 2.95 m Counterweight 13 300 kg Shoe 650 mm	7.5							*21 750	*21 750							*16 660	*16 660	8.86
	6.0					*26 890	*26 890	*23 170	*23 170	*21 180	18 030					*16 390	16 320	9.54
	4.5					*31 010	*31 010	*25 220	23 180	*22 040	17 550					*16 610	14 970	9.93
	3.0					*34 730	30 670	*27 250	22 190	*23 040	17 010					*17 290	14 300	10.1
	1.5					*36 770	29 420	*28 650	21 390	*23 730	16 530					*18 530	14 190	10.0
	0(Ground)					*36 890	28 790	*29 000	20 870	*23 670	16 210					*20 570	14 650	9.70
	-1.5															*21 580	15 880	9.12
Boom 8.4 m Arm 3.7 m Counterweight 13 300 kg Shoe 650 mm	-3.0	*41 880	*41 880	*39 690	*39 690	*31 580	28 780	*24 790	20 820						*21 270	18 440	8.23	
	-4.5			*30 900	*30 900	*24 390	*24 390								*19 710	*19 710	6.88	
	9.0									*16 350	*16 350				*12 240	*12 240	10.1	
	7.5									*17 010	*17 010	*15 370	14 260			*12 080	*12 080	10.9
	6.0					*25 050	*25 050	*20 700	*20 700	*18 220	17 840	*16 730	13 980			*12 200	12 090	11.4
	4.5					*29 780	*29 780	*23 250	22 410	*19 690	17 160	*17 530	13 600			*12 570	11 310	11.8
	3.0					*33 680	29 060	*25 600	21 310	*21 140	16 490	*18 380	13 190			*13 230	10 900	11.9
Boom 8.4 m Arm 4.4 m Counterweight 13 300 kg Shoe 650 mm	1.5							*27 270	20 490	*22 280	15 940	*19 060	12 840			*14 230	10 800	11.8
	0(Ground)							*28 030	20 000	*22 900	15 560	18 940	12 600			*15 730	11 020	11.6
	-1.5					*34 910	27 480	*27 840	19 800	*22 840	15 380	18 830	12 500			17 440	11 620	11.1
	-3.0					*32 930	27 660	*26 660	19 830	*21 880	15 400					*18 060	12 780	10.4
	-4.5					*29 640	28 080	*24 160	20 120	*19 410	15 680					*18 180	14 910	9.37
	-6.0			*29 450	*29 450	*24 260	*24 260	*19 260	*19 260							*17 670	*17 670	7.93
	9.0											*12 220	*12 220			*9 190	*9 190	11.0
Boom 8.4 m Arm 4.4 m Counterweight 13 300 kg Shoe 650 mm	7.5									*15 660	*15 660	*14 690	14 430			*8 980	*8 980	11.8
	6.0							*19 030	*19 030	*16 950	*16 950	*15 650	14 080	*11 380	11 210	*8 970	*8 970	12.3
	4.5					*27 220	*27 220	*21 660	*21 660	*18 520	17 290	*16 570	13 640	*13 920	10 990	*9 130	*9 130	12.6
	3.0					*31 550	29 580	*24 220	21 510	*20 110	16 550	*17 550	13 180	*15 820	10 730	*9 460	*9 460	12.7
	1.5					*32 210	28 130	*26 240	20 530	*21 460	15 910	*18 400	12 770	15 680	10 480	*9 990	9 670	12.7
	0(Ground)					*31 980	27 380	*27 420	19 890	*22 360	15 440	18 800	12 450	15 490	10 300	*10 790	9 830	12.4
	-1.5			*19 280	*19 280	*35 210	27 110	*27 700	19 550	*22 640	15 160	18 600	12 260			*11 980	10 290	12.0
Boom 8.4 m Arm 4.4 m Counterweight 13 300 kg Shoe 650 mm	-3.0	*19 410	*19 410	*27 940	*27 940	*33 840	27 150	*27 020	19 470	*22 150	15 080	*18 380	12 250			*13 800	11 160	11.3
	-4.5	*28 350	*28 350	*39 290	*39 290	*31 230	27 450	*25 210	19 640	*20 550	15 220					*16 510	12 680	10.4
	-6.0			*33 540	*33 540	*26 920	*26 920	*21 680	20 110	*16 670	15 730					*16 250	15 520	9.10

ZX870-5G

Rating over-front Rating over-side or 360 degrees Unit : kg

Conditions	Load point height m	Load radius m										At max. reach						
		3.0		4.5		6.0		7.5		9.0		10.5		meter				
		Rating over-front	Rating over-side or 360 degrees	Rating over-front	Rating over-side or 360 degrees	Rating over-front	Rating over-side or 360 degrees	Rating over-front	Rating over-side or 360 degrees	Rating over-front	Rating over-side or 360 degrees	Rating over-front	Rating over-side or 360 degrees	meter	meter			
Boom 8.4 m Arm 3.7 m Counterweight 13 300 kg Shoe 650 mm	9.0									*16 350	*16 350					*12 240	*12 240	10.1
	7.5									*17 010	*17 010	*15 370	13 970			*12 080	*12 080	10.9
	6.0					*25 050	*25 050	*20 700	*20 700	*18 220	17 500	*16 730	13 700			*12 200	11 830	11.4
	4.5					*29 780	*29 780	*23 250	21 980	*19 690	16 810	17 190	13 310			*12 570	11 070	11.8
	3.0					*33 680	28 460	*25 600	20 880	21 080	16 150	16 770	12 910			*13 230	10 660	11.9
	1.5									26 730	20 060	20 490	15 600	16 400	12 560	13 770	10 560	11.8
	0(Ground)									26 200	19 570	20 090	15 220	16 140	12 320	14 080	10 770	11.6
Boom 8.4 m Arm 4.4 m Counterweight 13 300 kg Shoe 650 mm	-1.5					*34 910	26 890	25 980	19 360	19 900	15 030	16 040	12 210			14 870	11 350	11.1
	-3.0					*32 930	27 060	26 020	19 400	19 920	15 050					16 380	12 490	10.4
	-4.5					*29 640	27 480	*24 160	19 690	*19 410	15 340					*18 180	14 590	9.37
	-6.0			*29 450	*29 450	*24 260	*24 260	*19 260	*19 260							*17 670	*17 670	7.93

LIFTING CAPACITIES (Without bucket)

Notes: 1. Ratings are based on ISO 10567.

2. Lifting capacity does not exceed 75% of tipping load with the machine on firm, level ground or 87% full hydraulic capacity.

3. The load point is the center-line of the bucket pivot mounting pin on the arm.

4. *Indicates load limited by hydraulic capacity.

5. 0 m = Ground.

For lifting capacities, subtract bucket and quick hitch weight from lifting capacities without bucket.

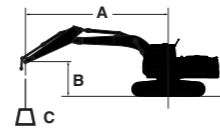

A: Load radius

B: Load point height

C: Lifting capacity

ZX870LCH-5G

Rating over-front Rating over-side or 360 degrees Unit : kg

Conditions	Load point height m	Loadradius m										Atmax.reach				
		3.0		4.5		6.0		7.5		9.0		10.5		meter		
		Rating over-front	Rating over-side or 360 degrees	Rating over-front	Rating over-side or 360 degrees	Rating over-front	Rating over-side or 360 degrees	Rating over-front	Rating over-side or 360 degrees	Rating over-front	Rating over-side or 360 degrees					
BE-Boom 7.1 m BE-Arm 2.95 m Counterweight 13 300 kg Shoes 650 mm	7.5							*21 750	*21 750					*16 660	*16 660	8.86
	6.0					*26 890	*26 890	*23 170	*23 170	*21 180	18 200			*16 390	*16 390	9.54
	4.5					*31 010	*31 010	*25 220	23 410	*22 040	17 730			*16 610	15 120	9.93
	3.0					*34 730	30 970	*27 250	22 420	*23 040	17 180			*17 290	14 450	10.1
	1.5					*36 770	29 730	*28 650	21 610	*23 730	16 710			*18 530	14 340	10.0
	0(Ground)					*36 890	29 090	*29 000	21 100	*23 670	16 390			*20 570	14 810	9.70
	-1.5			*42 330	*42 330	*35 250	28 900	*27 960	20 890	*22 120	16 320			*21 580	16 050	9.12
	-3.0	*41 880	*41 880	*39 690	*39 690	*31 580	29 080	*24 790	21 040					*21 270	18 640	8.23
	-4.5			*30 900	*30 900	*24 390								*19 710	*19 710	6.88
H-Boom 7.1 mm H-Arm 3.7 m Counterweight 13 300 kg Shoes 650 mm	7.5							*19 490	*19 490	*14 860	*14 860			*10 790	*10 790	9.47
	6.0							*21 670	*21 670	*19 100	18 730			*10 780	*10 780	10.1
	4.5			*39 260	*39 260	*28 980	*28 980	*23 970	*23 970	*21 110	18 200			*11 060	*11 060	10.5
	3.0					*33 260	32 070	*26 360	23 060	*22 410	17 610	*13 710	*13 710	*11 650	*11 650	10.6
	1.5					*36 220	30 580	*28 240	22 160	*23 470	17 060	*13 680	13 610	*12 620	*12 620	10.6
	0(Ground)					*37 340	29 670	*29 180	21 510	*23 940	16 640			*14 140	13 850	10.3
	-1.5					*36 660	29 250	*28 880	21 150	*23 400	16 420			*16 630	14 810	9.72
	-3.0			*44 080	*44 080	*34 090	29 230	*26 930	21 090					*21 140	16 760	8.88
	-4.5			*36 910	*36 910	*28 910	*28 910	*21 930	21 440					*21 120	20 860	7.66
H-Boom 8.4 m H-Arm 3.7 m Counterweight 13 300 kg Shoes 650 mm	9.0							*16 240	*16 240					*12 190	*12 190	10.1
	7.5							*16 890	*16 890	*15 320	14 310			*12 030	*12 030	10.9
	6.0					*24 900	*24 900	*20 570	*20 570	*18 090	17 910	*16 610	14 020	*12 150	12 120	11.4
	4.5					*29 600	*29 600	*23 100	22 500	*19 550	17 220	*17 400	13 630	*12 520	11 340	11.8
	3.0					*33 480	29 170	*25 430	21 390	*20 990	16 540	*18 240	13 230	*13 180	10 920	11.9
	1.5							*27 090	20 560	*22 120	15 980	*18 920	12 870	*14 180	10 820	11.8
	0(Ground)							*27 850	20 060	*22 740	15 600	18 820	12 620	*15 670	11 040	11.6
	-1.5					*34 700	27 580	*27 660	19 860	*22 680	15 420	18 710	12 520	*17 320	11 640	11.1
	-3.0					*32 720	27 770	*26 480	19 900	*21 730	15 440			*17 920	12 810	10.4
	-4.5					*29 440	28 200	*23 990	20 190	*19 270	15 730			*18 040	14 960	9.37
	-6.0			*29 240	*29 240	*24 070	*24 070	*19 110	*19 110					*17 520	*17 520	7.93

ZX870H-5G

Rating over-front Rating over-side or 360 degrees Unit : kg

Conditions	Load point height m	Load radius m										At max. reach				
		3.0		4.5		6.0		7.5		9.0		10.5		meter		
		Rating over-front	Rating over-side or 360 degrees	Rating over-front	Rating over-side or 360 degrees	Rating over-front	Rating over-side or 360 degrees	Rating over-front	Rating over-side or 360 degrees	Rating over-front	Rating over-side or 360 degrees					
H-Boom 8.4 m H-Arm 3.7 m Counterweight 13 300 kg Shoe 650 mm	9.0							*16 240	*16 240			*12 190	*12 190	10.1		
	7.5							*16 890	*16 890	*15 320	14 000	*12 030	*12 030	10.9		
	6.0					*24 900	*24 900	*20 570	*20 570	*18 090	17 540	*16 610	13 720	*12 150	11 840	11.4
	4.5					*29 600	*29 600	*23 100	22 040	*19 550	16 850	17 230	13 330	*12 520	11 070	11.8
	3.0					*33 480	28 530	*25 430	20 920	*20 990	16 170	16 800	12 920	*13 180	10 660	11.9
	1.5							26 790	20 090	20 530	15 610	16 430	12 570	13 780	10 550	11.8
	0(Ground)							26 260	19 590	20 130	15 230	16 160	12 320	14 090	10 760	11.6
	-1.5					*34 700	26 940	26 040	19 390	19 930	15 050	16 060	12 220	14 890	11 360	11.1
	-3.0					*32 720	27 130	26 080	19 430	19 950	15 070			16 410	12 500	10.4
	-4.5					*29 440	27 560	*23 990	19 720	*19 270	15 360			*18 040	14 610	9.37
	-6.0			*29 240	*29 240	*24 070	*24 070	*19 110	*19 110					*17 520	*17 520	7.93

TRANSPORTATION

UPPERSTRUCTURE

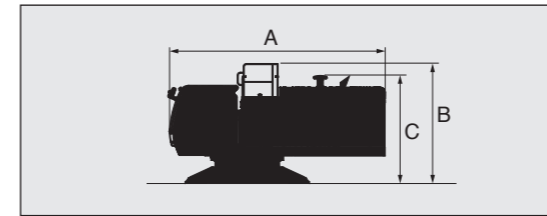

	Overall width	Weight	A	B	C
ZX870-5G / ZX870LC-5G	3 390 mm	27 400 kg	6 040 mm	3 370 mm	3 040 mm
ZX870H-5G / ZX870LCH-5G	3 390 mm	27 600 kg	6 040 mm		

SIDE FRAME

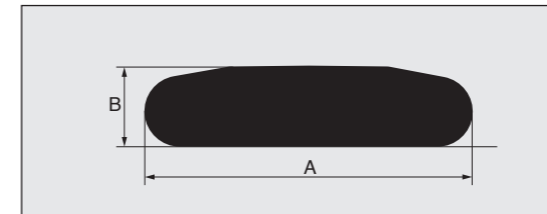

	Shoe width	Overall width	Weight	A	B
ZX870-5G	650 mm	1 330 mm	11 200 kg	5 840 mm	1 500 mm
	750 mm	1 330 mm	11 500 kg		
ZX870LC-5G	650 mm	1 330 mm	12 100 kg	6 360 mm	
	750 mm	1 330 mm	12 400 kg		
	900 mm	1 425 mm	12 900 kg		
ZX870H-5G	650 mm	1 330 mm	11 400 kg	5 840 mm	
ZX870LCH-5G	650 mm	1 330 mm	12 400 kg	6 360 mm	

COUNTERWEIGHT

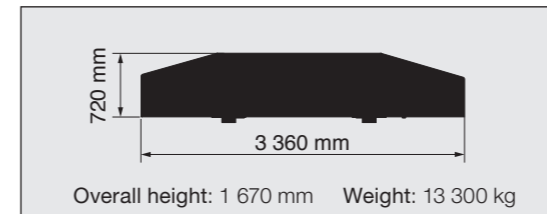

Overall height: 1 670 mm Weight: 13 300 kg

BASIC MACHINE (WITHOUT COUNTERWEIGHT)

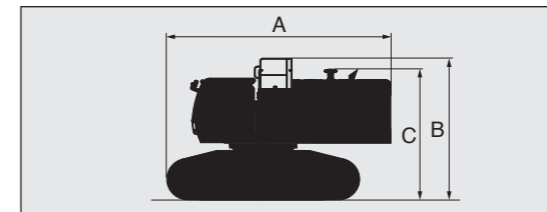

	Shoe width	Overall width	Weight	A	B	C
ZX870-5G	650 mm	3 480 mm	50 000 kg	6 770 mm	4 300 mm	3 960 mm
	750 mm	3 580 mm	50 700 kg			
ZX870LC-5G	650 mm	3 480 mm	51 800 kg	7 080 mm		
	750 mm	3 580 mm	52 500 kg			
	900 mm	3 730 mm	53 400 kg			
ZX870H-5G	650 mm	3 480 mm	50 700 kg	6 770 mm		
ZX870LCH-5G	650 mm	3 480 mm	52 600 kg	7 080 mm		

Note: Undercarriage retracted

BOOM

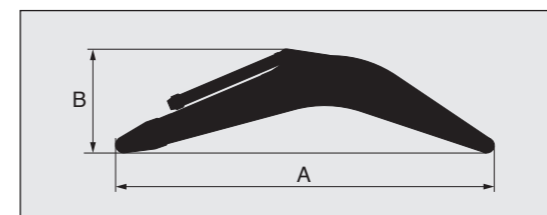

Boom	A	B	Overall width	Weight
7.1 m BE	7 490 mm	2 700 mm	1 450 mm	7 670 kg
8.4 m H	8 780 mm	2 500 mm	1 450 mm	8 200 kg
8.4 m	8 780 mm	2 500 mm	1 450 mm	8 200 kg

ARM

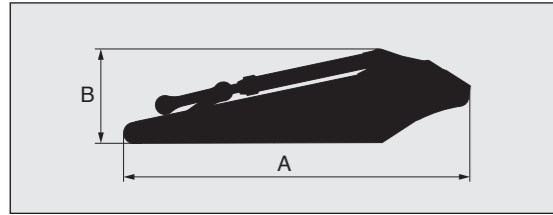

Arm	A	B	Overall width	Weight
2.95m BE	4 460 mm	1 660 mm	850 mm	4 650 kg
3.7m H	5 290 mm	1 420 mm	820 mm	4 510 kg
3.7m	5 290 mm	1 420 mm	820 mm	4 330 kg
4.4m	5 880 mm	1 420 mm	820 mm	4 660 kg

BUCKET

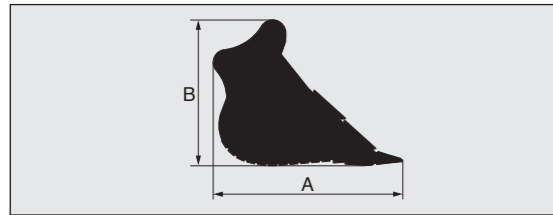

Bucket Capacity ISO heaped	A	B	Overall width	Weight
2.90 m ³	2 210 mm	1 910 mm	1 780 mm	2 700 kg
3.50 m ³	2 210 mm	1 910 mm	2 040 mm	2 950 kg
4.50 m ³	2 320 mm	2 000 mm	2 190 mm	3 970 kg
*1 3.50 m ³	2 240 mm	1 920 mm	1 890 mm	3 790 kg
*1 3.70 m ³	2 240 mm	1 920 mm	1 970 mm	3 900 kg
*1 4.30 m ³	2 310 mm	2 000 mm	2 110 mm	4 270 kg

*1:Rock Bucket

BOOM CYLINDERS 850 kg X 2 Overall height: 410 mm

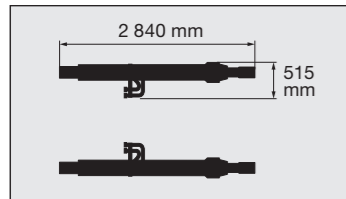

HOSE OF BOOM CYLINDERS 9 kg X 2 / 13 kg X 2

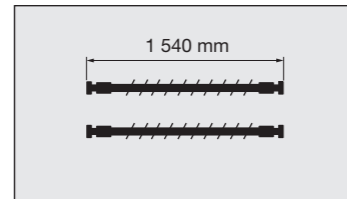

LEFT SIDEWALK Overall height: 150 mm

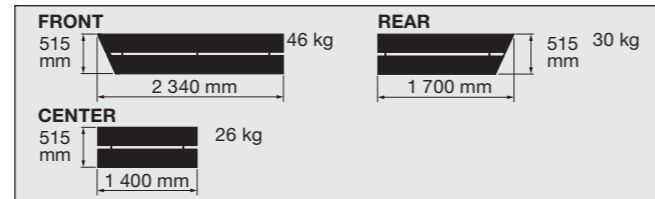

Standard and optional equipment may vary by country, so please consult your Hitachi dealer for details.

● : Standard equipment ○ : Optional equipment — : Not applicable

ENGINE	ZX870-5G	ZX870LC-5G	ZX870H-5G	ZX870LCH-5G
Auto idle system	●	●	●	●
Cartridge-type engine oil filter	●	●	●	●
Cartridge-type fuel filter	●	●	●	●
Dry-type air double filter with evacuator valve(with air filter restriction switch for monitor)	●	●	●	●
Fan guard	●	●	●	●
Fuel pre-filter	●	●	●	●
Power mood control [H/P (High Power) PWR(Power) ECO(Economy)]	●	●	●	●
Isolation-mounted engine	●	●	●	●
Pre-cleaner	○	○	○	○
Radiator, oil cooler with dust protective net	●	●	●	●
Radiator reserve tank	●	●	●	●
50 A alternator	●	●	●	●

HYDRAULIC SYSTEM				
Accessories for breaker	—	—	○	○
Accessories for breaker & crusher	—	—	○	○
Accessories for 2 speed selector	—	—	○	○
Auto power lift	●	●	●	●
Boom mode selector system	●	●	●	●
Control valve with main relief valve	●	●	●	●
Drain filter	●	●	●	●
Engine speed sensing system	●	●	●	●
E-P control system	●	●	●	●
Extra port for control valve	●	●	●	●
Full-flow filter	●	●	●	●
Hose rupture valve	○	○	○	○
Pilot filter	●	●	●	●
Power boost	●	●	●	●
Quick warm-up system for pilot circuit	●	●	●	●
Shockless valve in pilot circuit	●	●	●	●
Suction filter	●	●	●	●
Work mode selector	●	●	●	●

CAB				
Additional fuse box	●	●	●	●
Adjustable armrests	●	●	●	●
All-weather sound suppressed steel cab	●	●	●	●
AM-FM radio	●	●	●	●
Ashtray	●	●	●	●
Auto control air conditioner	●	●	●	●
Auto-idle selector	●	●	●	●
AUX. terminal and storage	○	○	○	○
Cab : (Center pillar reinforced structure)	●	●	—	—
OPG top guard fitted Level I (ISO10262) compliant cab	●	●	—	—
Round Tempered glass (green color) front window	●	●	—	—
Front window on upper, lower and left side can be opened	●	●	—	—

	ZX870-5G	ZX870LC-5G	ZX870H-5G	ZX870LCH-5G
H/R cab	—	—	●	●
OPG top guard fitted Level II (ISO10262)	—	—	●	●
OPG front guard fitted Level II (ISO10262)	—	—	○	○
Laminated straight glass front window	—	—	●	●
Left side window can be opened	—	—	●	●
Drink holder	●	●	●	●
Engine shut-off cable	●	●	●	●
Electric double horn	●	●	●	●
Evacuation hammer	●	●	●	●
Fire extinguisher bracket	○	○	○	○
Floor mat	●	●	●	●
Footrest	●	●	●	●
Front window washer	●	●	●	●
Glove compartment	●	●	●	●
Hot & cool box	●	●	●	●
Intermittent windshield wiper	●	●	●	●
Key cylinder light	●	●	●	●
LED room light with door courtesy	●	●	●	●
Pilot control shut-off lever	●	●	●	●
Rain guard for cab	○	○	—	—
Rear tray	●	●	●	●
Retractable seat belt	●	●	●	●
Rubber radio antenna	●	●	●	●
Seat : Adjustable reclining mechanical suspension	●	●	●	●
Seat : Adjustable reclining mechanical suspension with heater	○	○	○	○
Seat : Adjustable reclining air suspension with heater	○	○	○	○
Short wrist control levers	●	●	●	●
Storage box	●	●	●	●
Sun visor (front)	○	○	○	○
Sun visor (side)	○	○	○	○
Transparent roof with slide curtain	—	—	●	●
2 speaker	●	●	●	●
6 fluid-filled elastic mounts	●	●	●	●
12 V power outlet	○	○	○	○
24 V cigarette lighter	●	●	●	●

MONITOR SYSTEM				
Alarm buzzers: overhear, engine oil pressure	●	●	●	●
Alarms: overhear, engine warning, engine oil pressure, alternator, minimum fuel level, air filter restriction, work mode, etc	●	●	●	●
Display of meters: water temperature, hour, fuel rate, clock	●	●	●	●
Other displays: work mode, auto-idle, glow, operating conditions etc	●	●	●	●



Built on the foundation of superb technological capabilities, Hitachi Construction Machinery is committed to providing leading-edge solutions and services to contribute as a reliable partner to the business of customers worldwide.

Hitachi Environmental Vision 2050

Our Environmental Vision envisions a low-carbon society; a resource efficient society; a harmonized society with nature. To achieve such a sustainable society, we have established a set of long-term environmental targets called Hitachi Environmental Innovation 2050.

Reducing Environmental Impact by New ZAXIS

Hitachi makes a green way to cut carbon emissions for global warming prevention according to LCA*. New ZAXIS utilizes lots of technological advances, including the new ECO mode, and Isochronous Control. Hitachi has long been committed to recycling of components, such as aluminum parts in radiators and oil cooler. Resin parts are marked for recycling.

*Life Cycle Assessment – ISO 14040

Before using a machine with a satellite communication system, please make sure that the satellite communication system complies with local regulations, safety standards and legal requirements. If not so, please make modifications accordingly.

These specifications are subject to change without notice. Illustrations and photos show the standard models, and may or may not include optional equipment, accessories, and all standard equipment with some differences in color and features. Before use, read and understand the Operator's Manual for proper operation.